

⊙ BLUE SEAL

⊙ BLUE SEAL

⊙ BLUE SEAL

⊙ BLUE SEAL

⊙ BLUE SEAL

⊙ BLUE SEAL

⊙ BLUE SEAL

⊙ BLUE SEAL

⊙ BLUE SEAL

⊙ BLUE SEAL

⊙ BLUE SEAL

⊙ BLUE SEAL

⊙ BLUE SEAL

⊙ BLUE SEAL

⊙ BLUE SEAL

⊙ BLUE SEAL

⊙ BLUE SEAL

⊙ BLUE SEAL

⊙ BLUE SEAL

BLUE SEAL GAS BRATT PAN

MANUFACTURED BY

Moffat Limited
PO Box 10001
Christchurch
New Zealand
Ph: (03) 389 1007
Fax: (03) 389 1276

WORLD-WIDE BRANCHES**UNITED KINGDOM**

Blue Seal
Units 6-7, Mount Street Business Park
Mount Street, Nechells
Birmingham B7 5QU
Ph: (121) 327 5575
Fax: (121) 327 9711

UNITED STATES

Moffat Inc
3765 Champion Blvd
Winston-Salem
North Carolina 27115
Ph: (336) 661 0257
Fax: (336) 661 9546

CANADA

Serve Canada
22 Ashwarren Road
Downview
Ontario M3J1Z5
Toll Free: 800 263 1455
Ph: (416) 631 0601
Fax: (416) 631 0315
info@servecanada.com
www.servecanada.com
www.moffat.com

NEW ZEALAND**Christchurch**

Moffat Limited
PO Box 10-001
16 Osborne Street
Christchurch
Ph: (03) 389 1007
Fax: (03) 389 1276

Auckland

Moffat Limited
4 Waipuna Road
Mt Wellington
Auckland
Ph: (09) 574 3150
Fax: (09) 574 3159

AUSTRALIA**Victoria**

Moffat Pty Limited
740 Springvale Road
Mulgrave, Melbourne
Victoria 3171
Ph: (03) 9518 3888
Fax: (03) 9518 3838

New South Wales

Moffat Pty Limited
3/142 James Ruse Drive, Rose Hill
PO Box 913, Smithfield
Sydney, N.S.W. 2142
Ph: (02) 8833 4111
Fax: (02) 8833 4133

Western Australia

Moffat Pty Limited
PO Box 689
Joondalup Business Centre
WA 6027
Ph: (08) 9562 0263
Fax: (08) 9562 0385

Queensland

Moffat Pty Limited
30 Prosperity Place
Geebung, Brisbane
Queensland 4034
Ph: (07) 3630 8600
Fax: (07) 3630 8623

South Australia

Moffat Pty Limited
28 Greenhill Road
Wayville
South Australia 5034
Ph: (08) 8274 2116
Fax: (08) 8274 2129

In line with policy to continually develop and improve its products, Moffat Ltd. reserves the right to change the specifications and design without prior notice.

BLUE SEAL GAS BRATT PAN

MODELS - G580 MANUAL PAN TILT BRATT PAN
GE580 ELECTRIC PAN TILT BRATT PAN

<u>CONTENTS</u>	<u>PAGE</u>
SPECIFICATION	1
INSTALLATION	4
CONVERSION INSTRUCTIONS	7
OPERATING INSTRUCTIONS	8
CLEANING	10
SERVICING INSTRUCTIONS	11
WIRING SCHEMATIC -G580	15
-GE580	16
SPARE PARTS	17

Date Purchased..... Serial No.....
Dealer.....
Service Agent.....

SPECIFICATION

GENERAL

A heavy duty, Tilting Bratt Pan created for compact modular kitchens. Featuring full stainless steel pan construction, even heat distribution and thermostatic temperature control.

A. GAS SUPPLY REQUIREMENTS

	Natural Gas	LPG (Propane)	
Input Rate (Gas Consumption) - Bratt Pan	65 MJ/hr	65 MJ/hr	(Australia only) 65 MJ/hr
Supply Pressure	1.13 - 3.40 kPa (see note 1)	2.75 kPa (see note 2)	2.75 - 3.40 kPa (see note 3)
Burner Pressure	1.00 kPa	2.75 kPa	2.60 kPa (see note 4)
Gas Connection	3/4" B.S.P.		

Note 1:

Natural Gas models are supplied with an appliance regulator. Supply pressure is required to be within the minimum-maximum value stated for correct regulator operation and the regulator adjusted to the burner pressure specified.

Note 2:

LPG models (except Australia) operate directly off the supply pressure. Therefore the supply pressure to the appliance must be regulated to the burner pressure specified.

Note 3:

Australia Only - LPG models are supplied with an appliance regulator. Supply pressure is required to be within the minimum-maximum value stated for correct regulator operation and the regulator adjusted to the burner pressure specified.

Note 4:

The burner operating pressure is to be measured at the manifold test point with the burners operating at full setting. The operating pressure is ex-factory set, through the appliance regulator and is not to be adjusted, apart from when converting between gases, if required.

B. INJECTOR SIZES

MAIN BURNERS		PILOT BURNERS	
Nat. Gas	LPG (Propane)	Nat. Gas	LPG (Propane)
1.35 mm	0.90 mm	0.32	0.23

C. ELECTRICAL RATING

G580 - 220-240 V a.c, 50 Hz, 0.125A, 1P+N+E
GE580 - 220-240 V a.c, 50 Hz, 0.8A, 1P+N+E

SPECIFICATION

D. OVERALL DIMENSIONS

Height to Hob	915 mm.
Height to Splashback	1130 mm.
Width	900 mm.
Depth	812 mm.

E. PAN INTERNAL DIMENSIONS

Height	215 mm.
Width	810 mm.
Depth	500 mm.

F. WEIGHT (NETT)

Model G580	200kg.
------------	--------

G. PAN VOLUME

Model G580 / GE580 75 ltrs.

H. GAS CONNECTION

Gas connection point $\frac{3}{4}$ " BSP male thread located 50 mm from LH side, 305 mm from rear and 150 mm from floor.

I. WATER CONNECTION

Water connection R $\frac{3}{4}$ " male parallel flat face located 290 mm from LH side, 672 mm from rear and 310 mm from floor.

Maximum water supply pressure 550 kPa (80 psi).

SPECIFICATION

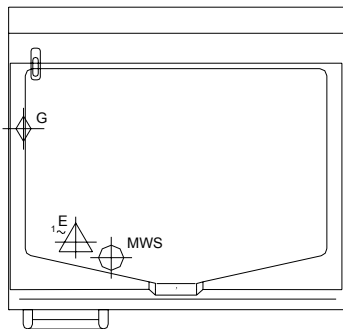
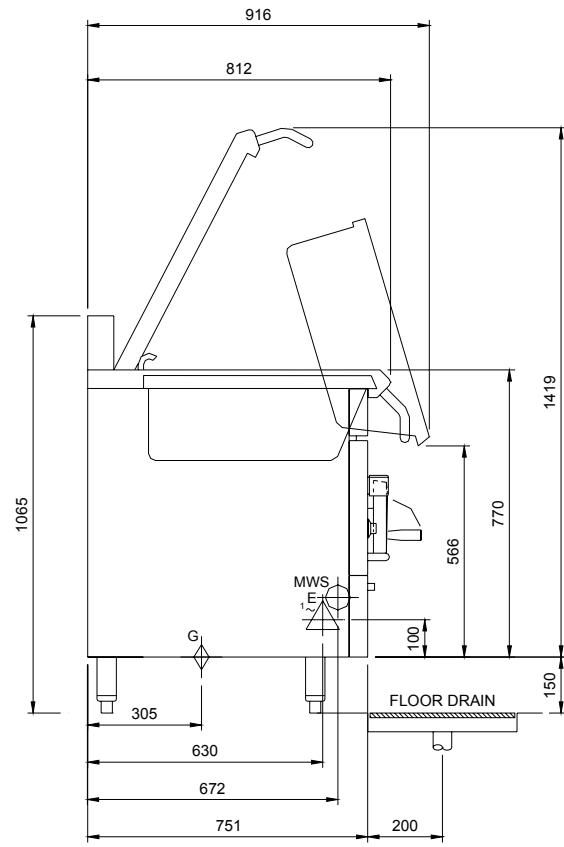
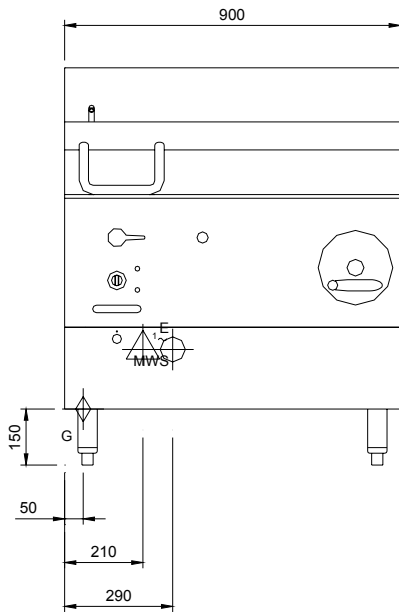

INSTALLATION

THIS APPLIANCE MUST BE INSTALLED TO THE REQUIREMENTS OF THE APPROVED LOCAL INSTALLATION CODE AND LOCAL AUTHORITY REQUIREMENTS, COVERING ELECTRICITY, GAS, FIRE, HEALTH, AND IN ACCORDANCE WITH NATIONAL INSTALLATION CODES:

- | | | |
|-------------------------|--------------|--------------------|
| - Australia | AS 5601 - | Gas Installations. |
| - New Zealand | NZS 5261 - | Gas Installation. |
| - Australia/New Zealand | AS/NZS3000 - | Wiring Rules. |

- i) DO NOT OBSTRUCT OR BLOCK THE APPLIANCES FLUE.
- ii) NEVER DIRECTLY CONNECT A VENTILATION SYSTEM TO THE APPLIANCE FLUE OUTLET.
- iii) INSTALLATION MUST ALLOW FOR A SUFFICIENT FLOW OF FRESH AIR FOR THE COMBUSTION AIR SUPPLY.
- iv) INSTALLATION MUST INCLUDE ADEQUATE VENTILATION MEANS, TO PREVENT DANGEROUS BUILD UP OF COMBUSTION PRODUCTS.

A. BEFORE ASSEMBLY AND CONNECTION

1. Check the type of gas, the specified operating pressure and the unit's hourly consumption. This information is clearly stated on the data plate which is located on the reverse side of the pan facia panel at the RH end. Tilt pan up to view.

2. The operating pressures for the respective gases are:

New Zealand and Australia

LP Gas 2.75 kPa (11 " WG).
Natural Gas 1.00 kPa (4.0" WG).

Pressures can be tested at the test point nipple on the gas control behind the bottom control panel. The working tolerance is plus 0.125 kPa, minus 0 kPa.

To alter the gas pressure (Natural Gas only), adjust the pressure regulator on the main gas control valve located behind the bottom front panel.

3. A regulator is an integral part in the main multi-function gas control with appliances for use on NATURAL GAS.

Australia only, LPG gas regulator is supplied for use on LPG (Propane). (These should be fitted only by a Licensed Gas Fitter).

4. After uncrating the unit check all the dismantled parts (legs, etc.) and "concealed" parts for transit damage. Report any damage to the carrier and dealer as soon as possible.

INSTALLATION

NOTE : This unit must only be installed on the adjustable feet supplied. It must not be fitted with rear rollers or castors as this unit is intended for stationary installations only.

B. ASSEMBLY

1. Tilt the appliance onto its LH side and fit both the front and rear RH legs on to the corresponding leg plates and secure each one in place with the hex bolt and spring washer supplied. Ensure that the bolts are securely tightened.
2. Lift up the LH side of the appliance and fit and secure the front and rear LH legs as described in (1) above.
3. Check that all the feet are in place and the attachment bolts are all securely tightened.
4. Adjust the four feet to make the unit steady and level.
5. To assemble handle, disassemble packaged handle assembly. Place shim packer and chromed stiffener on inside of lid. Place handle on outside of lid and screw up bolts with spring washer under each through stiffener and shim. Tighten bolts.

C. GAS CONNECTION

1. Gas connection point $\frac{3}{4}$ " BSP male thread located 50mm from LH side, 305mm from rear and 150 mm from floor. Location detail on services connections see specification drawing on page 3.
2. Appliances for use on LPG:-
 - Australia - $\frac{3}{4}$ " LPG gas regulator is supplied with each appliance. It must be installed in the gas line to this appliance.
 - Non Australia - No LPG regulator is supplied. Pressure is to be regulated at the supply.
3. It is important that adequately sized piping runs directly to the connection joint on the unit, with as few tees and elbows as possible to give maximum supply volume.
4. An accessible shut-off valve must be fitted on the supply line before the connection joint and pressure regulator.
5. A suitable joining compound which resists the breakdown action of LPG must be used on every gas line connection, unless compression fittings are used.
6. Check all connections for leakage. DO NOT USE A FLAME.

(NOTE: All connections to the gas supply must be by a Licensed Gas Fitter).

INSTALLATION

D. INSTALLATION CLEARANCES

	COMBUSTIBLES	NON COMBUSTIBLES
SIDES	25mm	0mm
BACK	25mm	0mm

E. WATER CONNECTION

Cold water mains R 3/4" male thread connection point. Location detail on services connections see specification drawing on page 3.

Maximum water supply pressure 550 kPa (80 psi).

Remove front lower service panel for access to the cold water connection.

F. ELECTRICAL CONNECTION

1. The electrical system are all connected through a 2m, 10 amp flex located at the LH side of the unit.
2. For immediate electric supply, simply fit plug and plug the lead into a properly earthed, 220-240V, 50 Hz, 1P+N+E, 3 pin socket.

G. COMMISSIONING

Before leaving the new installation, check that the electricity supply is correct and that the gas pressures are correct to B, Page 1. Check that the water supply is connected and not leaking .

Then check operation of the unit as detailed in OPERATING INSTRUCTIONS (Page 8).

NOTE: If for some reason it is not possible to get the appliance to function correctly, then contact the supplier.

NOTE: Shut off the gas supply and remove the electrical plug from the wall before any maintenance work is done on the appliance.

CONVERSION INSTRUCTIONS

IMPORTANT:

These conversions should only be carried out by a qualified Gas Fitter. All corrections must be checked for leaks before recommissioning appliance.

Appliances for use on Natural Gas - the regulator is incorporated in the main gas control of the appliance, consisting of an adjustable regulator spring and screw cap.

Appliances for use on LPG:-

- Australia - Use LPG gas regulator supplied with each appliance. It must be installed in the gas line to this appliance.
- Non Australia - No LPG regulator is supplied. Pressure is to be regulated at the supply.

For all full gas type conversions it is necessary to remove the main front panel. To remove, firstly remove the handwheel (G580) with pan down, then remove front panel by removing 3 retaining screws at the bottom for the panel. Refit hand wheel to allow pan to be raised/lowered during conversion procedure. Before starting conversion ensure the gas and electrical supplies are off.

MAIN BURNERS

1. Tilt pan fully.
2. Unscrew and lift out all burners.
3. Determine correct injector sizes from the data plate located on inside face of the pan fascia panel for corresponding gas.
4. Remove the injectors from the manifold by unscrewing in anti-clockwise direction from the front of the unit with the control panel removed.
5. Drill them out or replace with the correct size injector.
6. Reassembly is the reversal of Steps 2-5.

PILOT BURNER

1. Remove ignitor electrode, disconnect pilot supply tube from pilot burner with 10mm spanner.
2. Replace injector with correctly sized injector to size stated on data plate located on inside face of the pan fascia panel for corresponding gas.
3. With pilot supply tubes disconnected, remove existing pilot orifice spuds and replace with correct size for gas.
4. Reassembly of pilot is reversal of Steps 1-3.

GAS CONTROL REGULATOR

For Natural Gas operation the regulator is incorporated in the main gas control of the appliance consisting of an adjustable regulator spring and screw cap.

Appliances for use on LPG:-

- Australia - $\frac{3}{4}$ " LPG gas regulator is supplied with each appliance. It must be installed in the gas line to this appliance.
- Non Australia - No LPG regulator is supplied. Pressure is to be regulated at the supply.

Convert the gas control accordingly, check and adjust the operating pressure to that stated on the data plate located on the inside face of the fascia panel.

IMPORTANT: These conversions should only be carried out by a qualified Gas Fitter. All corrections must be checked for leaks before re-commissioning appliance.

OPERATING INSTRUCTIONS

G580

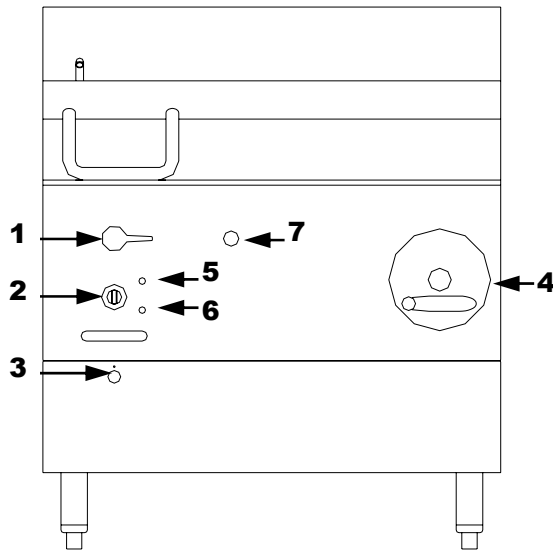

DESCRIPTION

- 1 Water Tap.
- 2 Thermostat.
- 3 Gas Control.
- 4 Pan Tilt Handle.
- 5 Power Indicator.
- 6 Thermostat ON/OFF Indicator.
- 7 Burner Viewing Hole.

GE580

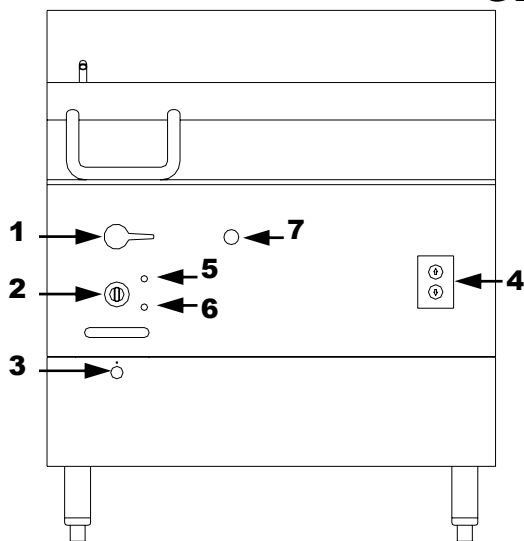

DESCRIPTION

- 1 Water Tap.
- 2 Thermostat.
- 3 Gas Control.
- 4 Pan Tilt Control Switches.
- 5 Power Indicator.
- 6 Thermostat ON/OFF Indicator.
- 7 Burner Viewing Hole.

ENSURE THAT POWER IS CONNECTED TO THE APPLIANCE.

LIGHTING PILOT BURNER

- i. Rotate the thermostat control knob (2) to **★**. The power indicator light(s) should come on.
- ii. Rotate and depress the gas control knob (3) at position marked **★**. With knob depressed, a spark will be generated at the pilot burner.
- iii. Once the pilot is lit (view through viewing port at front). Hold in control knob (3) for approx. 10 seconds, then release. Pilot burner should remain alight. If not repeat above procedure.

NB. Lighting of the pilot burner can be done with the pan up or down.

OPERATING INSTRUCTIONS

LIGHTING MAIN BURNERS

Once pilot burner is alight, operation of main burners can occur. To light:-

- i. Rotate control knob (3) to position marked .
- ii. Rotate the thermostat knob (2) to the desired position. Main burners will now ignite automatically off the pilot burner.

NB. Main Burners will only operate when the pan is in the flat cooking position. Tilting the pan up will automatically shut-off burners.

SETTING TEMPERATURE

Turn thermostat control knob to desired Gas Mark. The temperature will be thermostatically controlled at this selected heat setting.

NB. The pilot burner must be lit and the gas control knob (3) in the  position for the heating system to operate.

WATER

The control thermostat needs to be turned ON to hold solenoid water supply valve open and enable water supply to the appliance.
To add water to the cooking product or for cleaning, turn the water tap anti-clockwise with the pan in the down position and the pan lid up.
The water flow can be controlled by adjusting the water tap position.

NB. ¼ turn anti-clockwise is FULLY open.

TILTING THE PAN - G580 ONLY



To tilt the pan, turn the handle clockwise. The burners will automatically turn off when the pan is raised.
With the pan returned to its down position, the burners will re-ignite.

TILTING THE PAN - GE580 ONLY

To tilt the pan up or down, depress the tilt control switch on the front panel with the corresponding direction arrow marking and hold depressed as long as required. Releasing the switch will stop the tilt operation and the pan will rest in the chosen position.

NOTE: The electric lift mechanism will only operate if the pan lid is in the raised position.

TURNING OFF

To turn off the unit, set the thermostat control knob (2) to the  (OFF) position. The unit will now not operate, however the pilot burner will remain lit.
To turn the pilot burner off, rotate the gas control knob to the  (OFF) position by depressing and turning clockwise.

CLEANING

EXTERIOR

Clean with detergent. Baked on deposits or discoloration may require a good quality stainless steel cleaner or stainless steel wool. Always apply cleaner when the unit is cool and rub in the direction of the "grain".

PAN

Do not use wire brushes. Clean the pan regularly after each use.

MAINTENANCE

To achieve the best results cleaning must be regular and thorough and all controls and mechanical parts checked and adjusted periodically by a competent serviceman. If any small faults occur, have them attended to promptly. Don't wait until they cause complete breakdown.

REMEMBER: THE ELECTRICAL & GAS SUPPLIES MUST BE OFF DURING CLEANING OR MAINTENANCE.

SERVICING INSTRUCTIONS

BLUESEAL Bratt Pans are designed and engineered for serviceability. Any part can be quickly and easily removed for service or replacement from the front of the unit.

CAUTION: Before carrying out any service work ensure that the gas supply line is shut down and/or disconnected.

NOTE: All servicing must be carried out by an authorised person. It is recommended that the unit is periodically checked every six months.

EXPLANATION OF CONTROL SYSTEM

The gas control circuit in this Bratt Pan is operated by two circuits, a millivolt circuit and a mains voltage circuit.

The first is the pilot system which consists of the thermocouple, the pilot burner and the gas control.

Heat on the thermocouple from the pilot flame generates a 20-30 mV electrical potential between the thermocouple and earth. This millivolt circuit connected to the gas control valve is enough to hold the pilot valve magnet within the gas control open, thereby allowing the pilot burner to operate.

The mains voltage circuit consists of the thermostat and the gas control. When the thermostat calls for heat, this energizes the main burner valve magnet within the gas control, allowing the magnet to pull open the main burner valve and this passes gas through to the burners.

This main valve circuit is interrupted by the thermostat as the thermostat cycles on/off, it open and closes the gas control circuit, thereby opening and closing the main burner valve to cycle the main burners on/off. A microswitch also opens the circuit when the pan is raised from the flat cooking position.

The overtemperature thermostat is included in the mains voltage circuit so that when it open circuits it cuts the electrical supply to the main burner valve magnet, thereby shutting off the main burners to prevent pan damage (The power indicator will go out). The Bratt Pan then becomes inoperable until the Pan cools to below 280°C in which the overtemperature thermostat can be reset again and allow the mains voltage circuit to be complete and thereby the main burners will ignite again.

NB. The overtemperature cutout is found through the pilot sight hole on the left side. Press the button to reset.

Piezo Ignitor Not Sparking - The most common cause will be a short in the high tension lead. If repeated sparking of the piezo shows intermittent sparking at the electrode, then the lead should be traced to find area of short. This can normally be visually seen as the spark arcs. If the lead is shorting the best solution is to replace it, as the electrical insulation strength of the lead may have deteriorated.

If the spark arc can be seen at the electrode insulator at the pilot burner instead of at the electrode tip, then the insulator probably has a fracture and should be replaced.

SERVICING INSTRUCTIONS

If no spark at all can be generated, check that there is power to the unit and then the ignitor circuit. Check that there is continuity through the ignitor switch located on the gas control and the wiring is secure to the ignitor. If correct the ignitor has failed.

Note: If ignition system fails, the pilots can be manually lit in the interim until the piezo circuit is repaired. A standard taper torch or matches/lighter can be used for manual back-up ignition.

Pilot Burner Will Not Light/Stay Alight - Firstly check thermocouple connection is firm. A loose connection will cause resistance to millivolt circuit and result in pilot outage.

If connection OK, verify that there is gas at the pilot burner when the control knob is held in the pilot position by manually lighting or using ignition system. If there is no gas flow or very little, check supply is not empty or shut off further downstream. If pilot can be lit but flame too small to impinge on thermocouple, again check supply and if OK, check adjustment of pilot flow by adjusting screw below control knob on gas control. If sufficient pilot flame cannot be obtained, remove pilot orifice from pilot burner and check for blockages and/or correct size.

LP Gas	0.23mm
Natural Gas	0.32mm

If pilot flame is OK but goes out after control knob released (after holding in for approximately 20 seconds), then the thermocouple may be faulty.

Disconnect the thermocouple from the gas control, while holding in the control knob in the pilot position and using a multimeter measure the millivolts being generated between the thermocouple end and earth (place other probe of multimeter on body of gas control). With thermocouple hot, millivolt reading should be between 20-30 mV. If voltage reading below 15 millivolts the thermocouple is defective and should be replaced.

If all of the above in the pilot and thermocouple system check out OK, then gas control valve is defective and needs replacement.

Pilot Burner Delay in Ignition of Main Burners - Check operating pressure as stated in installation instructions, Page 4. Check pilot flame adjustment; pilot flame for main burner ignition should be approximately 20 mm long. Increase by adjusting pilot adjustment screw on gas control.

Check pilot orifice size correct. (See Specifications Pg 1).

Overtemperature Thermostat Cuts Out

- This would occur for one of three reasons:

- 1) Overtemperature thermostat faulty. If cutting out main burners and the power indicator light also goes below 320°C then replace overtemperature thermostat.
- 2) Control thermostat not maintaining set temperature.

- Cause:
- i) Out of calibration.
 - ii) Thermostat does not open on temperature rise.

SERVICING INSTRUCTIONS

Check continuity through thermostat leads on temperature rise. If circuit does not open replace thermostat.

- 3) Thermostat opens on temperature rise but control valve does not respond. Check connections on gas control are correct. If correct, replace gas control valve.

Main Burners Do Not Come On - Firstly check power is supplied to the unit. Check pan is flat so that the microswitch circuit is closed. Check thermostat setting correct and gas control knob in main burner on position.

If the microswitch requires adjusting, slacken off the two screws holding the microswitch bracket to the control mounting panel. Adjust height to achieve the microswitch is activated when the pan is completely down in the flat cooking position.

No Pan Filling Water Available - The manual water fill valve has an electrical solenoid isolating valve fitted to the supply side of the water supply plumbing in the appliance. The shut-off valve only opens water supply to manual valve, when the pan is in down position, and when the control thermostat is turned ON.

If the pan is in down position, control thermostat is ON and main outside water supply is turned ON, check that the solenoid valve has electrical supply across its coil terminals. Access to solenoid valve is by removing lower front service panel. If solenoid coil has power, but no water available on turning the manual valve, check coil for open circuit, short circuit and for solenoid coil burn-out. Replace solenoid, if necessary.

If coil OK, disconnect water connection and check inlet filter screen for foreign matter blockage. Clean and refit, if necessary.

If no voltage to solenoid coil, check for electrical fault in pan lift microswitch circuit. A fault here is likely to also cause the main burners to be not operational.

REPLACEMENT OF PARTS PROCEDURE

Access - Front Lower Control Panel

Undo the three screws along the bottom edge of the Bratt Pan. Lower control panel can now be removed.

Access - Front Upper Control Panel

Prise off the handwheel cap and remove the handwheel (not GE580). Prise out the water valve handle insert and undo the screw securing the handle to the tap. Remove the handle and undo the water valve cover plate. Remove two screw along bottom edge of the panel. Upper control panel can now be positioned open for servicing by retaining straps on both sides of the panel. To completely remove the upper panel, wiring to thermostat and LEDs, and the retaining straps must be removed.

Thermocouple

Disconnect from gas control. Unscrew securing nut from pilot burner. Remove. Replace thermocouple and reconnect.

SERVICING INSTRUCTIONS

Pilot Burner

Disconnect thermocouple from pilot burner as described above. Disconnect pilot supply tube from pilot burner by unscrewing nut and olive. Disconnect piezo ignition lead. Remove pilot burner securing screw(s) and remove pilot burner assembly. Replace with new unit by reversing above procedure.

N.B. Pilot burner comes complete with new piezo electrode.

Ensure correct pilot orifice is refitted. See Specifications Pg 1.

Thermostat (Replacement)

Lift pan fully up.

Remove capillary block located at the middle front base of the pan (2 x M6 nuts) and gasket. Take out thermostat capillary from locating groove.

Remove thermostat control knob and 2 slot screws from control panel. Disconnect wiring from thermostat terminals.

Replace thermostat and reassembly in the reverse of the above procedure.

Overtemperature Thermostat (Replacement)

Lift pan fully up.

Remove capillary block located at the middle front base of the pan (2 x M6 nuts) and gasket. Take out thermostat capillary from locating groove.

Remove 2 slot screws from overtemperature bracket. Disconnect wiring from terminals.

Replace overtemp and reassembly in the reverse of the above procedure.

Main Gas Control (Replacement)

Should replacement of main gas control be necessary.

Undo Mack union and main burner gas connection. Disconnect the thermocouple, ignitor switch and gas control solenoid connection.

Remove 4 screws attaching the control to the control panel.

Replace gas control in assembly.

Refit by reversing above procedure.

Water Solenoid Valve

Isolate water supply at source and disconnect electrical power supply. With lower service panel removed, disconnect electric wires from solenoid terminals and water plumbing from inlet and outlet connections to the water solenoid valve. Remove solenoid valve assembly from appliance and replace it.

Reassemble the solenoid valve and fully check for water leaks and correct operation.

WIRING DIAGRAM - MANUAL LIFT

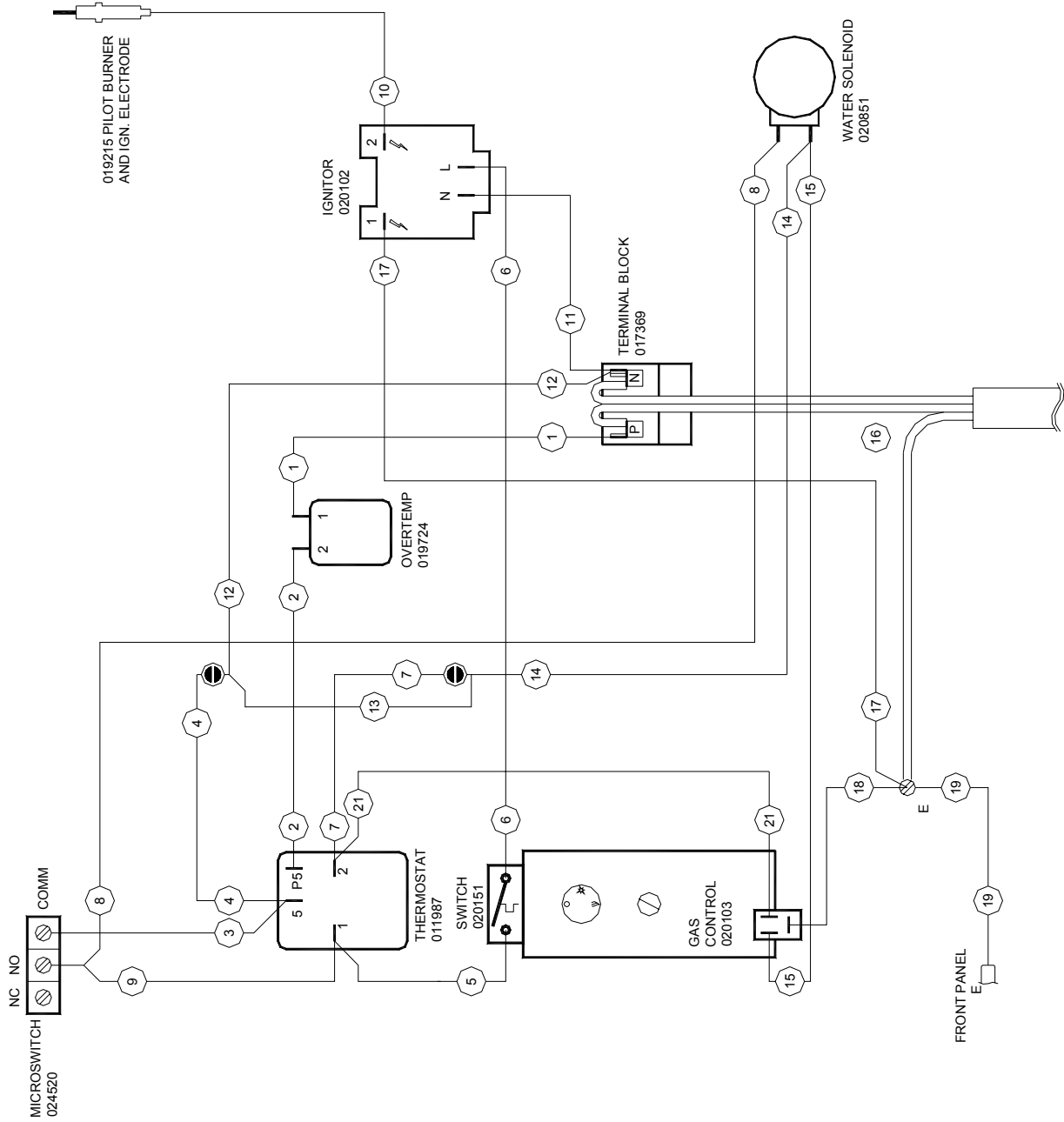

WIRING DIAGRAM - ELECTRIC LIFT

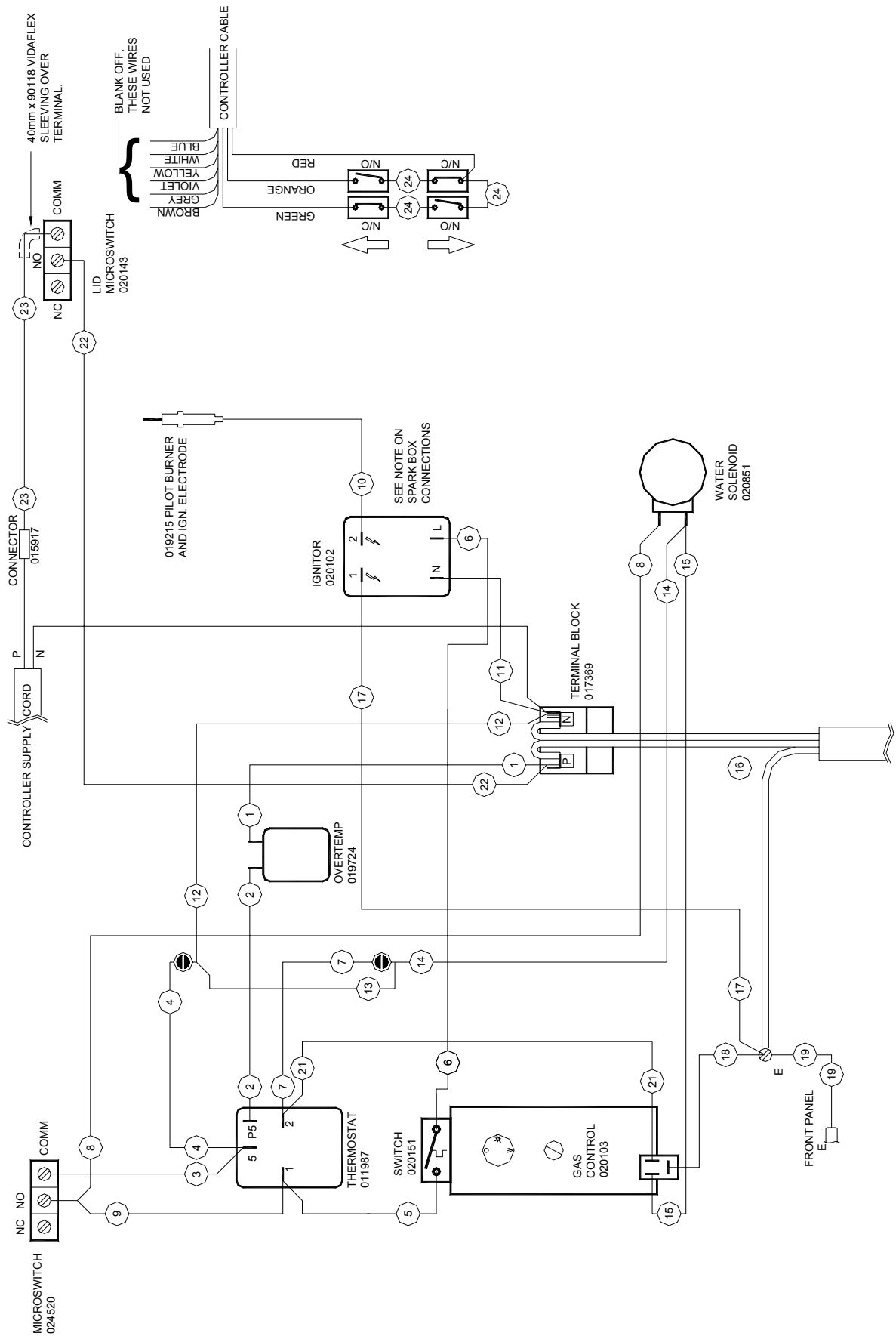

SPARE PARTS

Part No	Description	
022400	Burner.	
036090	Burner Injector	Ø0.90 mm - LPG.
036135	Burner Injector	Ø1.35 mm - Natural Gas.
019215K	Pilot Burner.	
019217	Pilot Injector	Ø0.23 mm - LPG.
018693	Pilot Injector	Ø0.32 mm - Natural Gas.
019429	Thermocouple.	
018743	Thermocouple Spacer.	
018744	Pilot Electrode.	
020060	H.T Lead.	
020102	Ignitor.	
020104	Ignition Switch.	
020103K	Gas Control.	
017369	Terminal Block.	
011987	Thermostat 50°C - 320 °C.	
015560	Thermostat Knob.	
019724	Over-Temp 420 °C.	
013528	Indicator Neon.	
024520	Microswitch.	
020062	Water Valve.	
023890	Water Valve Handle.	
020851	Water Solenoid Valve.	
020073	Lid Handle.	
020059	Handle Stiffener.	
020035	Handle Bar Shim.	
019795	Lid Hinge Spring - RH.	
019794	Lid Hinge Spring - LH.	
020173	Capillary Block Gasket.	
020043	Bearing & Housing	(Manual Lift Only).
020030	Handwheel	(Manual Lift Only).
020069	Handwheel Spacer Bush	(Manual Lift Only).
044400	Key Woodruff - 7/8" X 5/32"	(Manual Lift Only).
044066	Handle Nut - M16 X 2	(Manual Lift Only).
020184	Pan Gasket.	
018724	Leg Assembly.	
020389	Linear Actuator	(Electric Lift Only).
020390	Actuator Controller	(Electric Lift Only).
020143	Microswitch - Lid	(Electric Lift Only).
020392	Button Switch - 'Down'	(Electric Lift Only).
020393	Button Switch - 'Up'	(Electric Lift Only).
020394	Push Button Switch N/O	(Electric Lift Only).
020395	Push Button Switch N/C	(Electric Lift Only).
026632	Regulator 3/4" -	(LPG [Propane] Australia only).
020222	Conversion Kit	Nat → LPG.
020229	Conversion Kit	LPG → Nat Gas.

